

Renesas Technology to Release CRD5CM, the Industry's First Reverse Conducting Thyristor for Use in Regulators for Two-Wheeled Vehicles

— Integration of two elements into a single element in a single package, enabling regulators that are more compact and lower in cost —

Tokyo, January 12, 2010—Renesas Technology Corp. today announced the CRD5CM reverse conducting thyristor*¹ for use in voltage regulators for two-wheeled vehicles and engines for general-purpose batteries. The CRD5CM integrates a thyristor*² and a rectifier diode in a single element. Sample shipments will begin in February 2010 in Japan.

The CRD5CM is suitable for use in two-wheeled vehicles, where demand for compact size and low price is particularly strong. The market for such vehicles is expected to grow in countries such as China, India, and Indonesia. The main features of the CRD5CM are described below.

- (1) The industry's first reverse conducting thyristor with compact package for use in regulators for two-wheeled vehicles

In addition to being the industry's first reverse conducting thyristor for use in regulators for two-wheeled vehicles, the TO-220 package of the CRD5CM is the same as that used for previous thyristor (single-element) products. This means the mounting area can be reduced by about 50%, making it possible to design regulators that are more compact and less costly thanks to the reduced component mounting cost.

- (2) Thyristor with rated current of 5 A and rated voltage of 400 V

Though integrated into a single, compact package, the thyristor employs Renesas Technology's high-quality planar structure to achieve a rated current of 5 A, a rated voltage of 400 V, and a surge-on current*³ of 80 A (50 Hz). This enables it to handle surge current during switching, etc.

- (3) Diode with rated current of 5 A and soft turn-off characteristics

Though integrated into a single, compact package, the diode employs Renesas Technology's high-quality planar structure to achieve a rated current of 5 A and a surge-on current of 80 A (50 Hz). Also, the regulators of two-wheeled vehicles require rectifier diodes with soft reverse recovery characteristics. The diode of the CRD5CM has soft turn-off characteristics, with a reverse recovery time*⁴ of 4.0 μ s (typ.) that limits voltage surges during commutation.

The thermal resistance of the CRD5CM with TO-220 package is 2.8°C/W. Operation is guaranteed up to 150°C, allowing a smaller cooling fan in the system.

< Product Background >

Two-wheeled vehicles and engines for general-purpose batteries employ a regulator between the generator and battery to prevent current flow at a voltage higher than the battery's storage voltage value. They regulate the voltage by switching the current flow from the generator on and off. For a three-phase regulator this block has typically consisted of three sets of thyristors and diodes, each in its own package.

(■ See example application circuit.)

As batteries have become more compact and less costly in recent years, demand has grown for associated devices that are compact and contribute to lower overall system cost.

Renesas Technology already mass produces thyristors for use in two-wheeled vehicles and other applications, and they have gained wide adoption. Now, in response to the market requirements outlined above, the company has utilized its accumulated design process technology and element layout expertise to integrate the thyristor and diode into a single element. The new CRD5CM reverse conducting thyristor uses the same package as a standard thyristor. It makes it possible to design regulators that are more compact and less costly.

Renesas Technology will continue to develop new products in this category, expanding its lineup in a timely manner with models offering larger current capacity.

< Notes >

- Notes:
1. Reverse conducting thyristor: Thyristor and rectifier diode are integrated into a single element and an antiparallel configuration.
 2. Thyristor: A three-pin (gate, cathode, anode) semiconductor conducts between anode and cathode when current flows from the gate to the cathode.
 3. Surge-on current: The maximum current value instantaneously.
 4. Diode reverse recovery time: Current flows through the diode in the forward direction, but reverse current flows when reverse voltage (VR) is applied. The duration until the reverse current flow stops is the reverse recovery time.

* Product names, company names, or brands mentioned are the property of their respective owners.

< Typical Applications >

- Two-wheeled vehicles
- General-purpose batteries

< Prices in Japan > *For Reference

Product Name	Package	Sample Price [Tax Included] (Yen)
CRD5CM	TO-220	50

< Example application circuit >

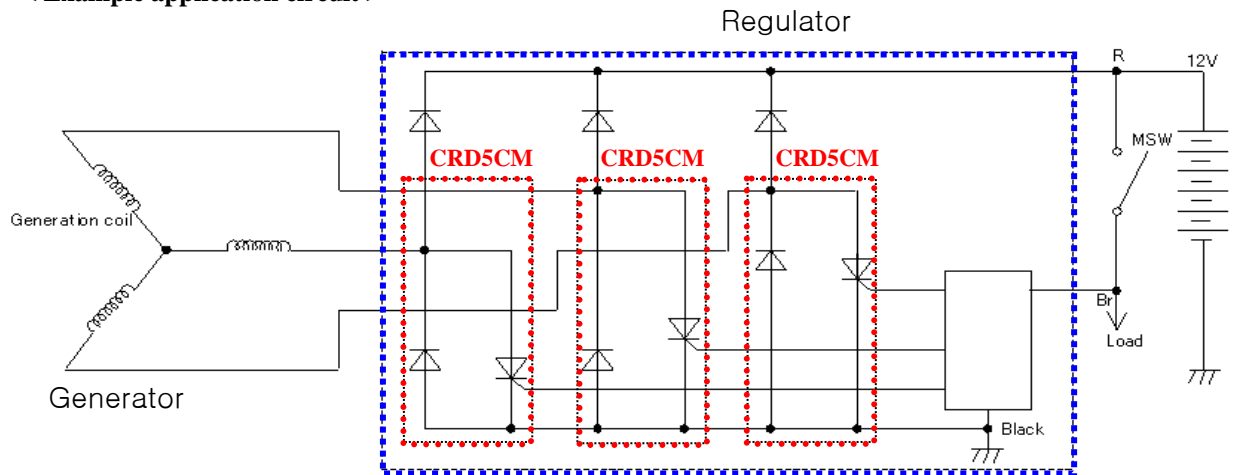

< Specifications >

Item	(Symbol)	Description
Product name		Reverse conducting thyristor
Configuration		Thyristor + diode
Package		TO-220
Reverse-blocking thyristor		
Rated voltage	(VDRM)	400 V
Rated current	(IT)	5 A
Surge-on current	(ITSM)	80 A
On-voltage	(VT)	1.25 V (typ.) @ IT = 10 A
Gate trigger current	(IGT)	30 mA
Diode		
Rated forward current	(IF)	5 A
Surge current	(IFSM)	80 A
Forward voltage	(VF)	1.25 V (typ.) @ IF = 10 A
Reverse recovery time	(trr)	4.0 μs (typ.)

- ### -

*** Information contained in this news release is current as of the date of the press announcement, but may be subject to change without prior notice. ***